

# Red Dragon Flex-Tow Hitch

## Mounting and Operating Instructions For Model B-100 Bumper Mount Unit

The Red Dragon Flex-Tow hitch is bolted directly to the bumper of pickup trucks and similar sized vehicles. All necessary hardware for installing the Red Dragon Flex-Tow Hitch is packaged and included in the carton. The hardware package includes the following:

- 4 - 7/16" x 1 1/2" Bolts, Nuts & Lock-Washers
- 2 - 7/16" x 2 1/2" Bolts and Self-Locking Nuts
- 1 - 7/16" x 3" Bolt and Self-Locking Nut
- 1 - Hardened Clevis Pin, Hair pin Clip, Cotter Key and Chain
- 8 - 7/16" Flat Washers

### Mounting Instructions:

1. Clamp or block the bumper mounting assembly B-103 to the bumper in the desired position. Drill four 29/64" holes in bumper using the predrilled holes in the bumper mounting assembly as guides. Secure bumper mounting assembly to frame using four 7/16" x 1 1/2" bolts, lock washers and nuts provided.
2. Place end of clevis arm A-101 into either of the brackets on bumper mounting assembly and secure with 7/16" x 2 1/2" bolt and self-locking nut.
3. Place end of idler arm A-102 into the other bracket on the bumper mounting assembly and secure with 7/16" x 2 1/2" bolt and self-locking nut.
4. Bring both arms together to form a triangle. Secure with the 7/16" x 3" bolt and self-locking nut.
5. The assembled hitch is held in vertical position by a hardened clevis pin and hairpin clip. To prevent loss, this pin should be attached to the frame mounting assembly with the chain and cotter key provided (see diagram for location of pin). NOTE: If the arms are not in a vertical position with pin inserted, remove the pin, move the arms to the desired position, and drill a new 1/4" hole near the existing holes. Insert pin in new hole.

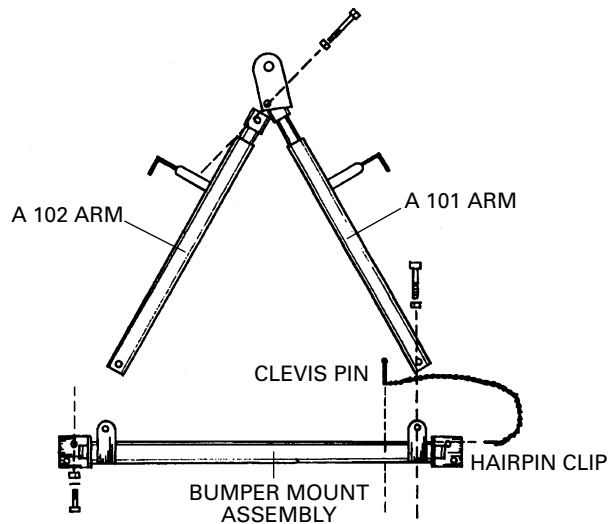
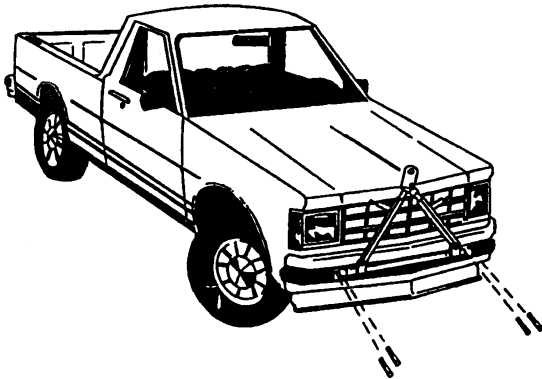

### Operating The Red Dragon Flex-Tow Hitch

You may move your hitch from side to side, forward and rearward, to attach to the towing vehicle. Attach hitch to the draw bar of the towing vehicle. As towing begins, the telescoping arms will extend. When the telescoping arms reach full extension, the spring loaded pins lock into place making the Flex-Tow rigid.

When finished towing, lift the arms and replace the clevis pin in the frame mounting assembly. Pull the locking pins out one at a time and slide the telescoping arms in.

A small amount of lubricant at the point where the spring loaded pin contacts the telescoping arm may improve operation.