

Red Dragon Models AG-235, AG-235A and AG-235B Construction Heater

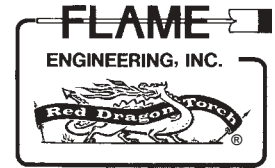

A TOTALLY NEW DESIGN!

Indoor use for temporary heating of buildings under construction. Use propane only.

THIS HEATER IS DESIGNED AND APPROVED FOR USE AS A CONSTRUCTION HEATER UNDER ANSI Z83.7 IN ACCORDANCE WITH AMERICAN GAS ASSOCIATION AND THE CANADIAN GAS ASSOCIATION, INSTALLATION CODES FOR PROPANE BURNING APPLIANCES AND EQUIPMENT B 149.2, AS OF SEPTEMBER 13, 1993.

**GENERAL HAZARD WARNING:
FAILURE TO COMPLY WITH THE
PRECAUTIONS AND INSTRUCTIONS PROVIDED
WITH THIS HEATER CAN RESULT IN DEATH,
SERIOUS BODILY INJURY AND PROPERTY
LOSS OR DAMAGE FROM HAZARDS OF FIRE,
EXPLOSION, BURN, ASPHYXIATION, CARBON
MONOXIDE POISONING, AND/OR ELECTRICAL
SHOCK. ONLY PERSONS WHO CAN
UNDERSTAND AND FOLLOW THE
INSTRUCTIONS SHOULD USE OR SERVICE
THIS HEATER. IF YOU NEED ASSISTANCE OR
HEATER INFORMATION SUCH AS AN
INSTRUCTIONS MANUAL, LABELS, ETC.
CONTACT THE MANUFACTURER.**



WARNING:
**FIRE, BURN, INHALATION, AND
EXPLOSION HAZARD. KEEP SOLID
COMBUSTIBLES, SUCH AS BUILDING
MATERIALS, PAPER OR CARDBOARD, A
SAFE DISTANCE AWAY FROM THE
HEATER AS RECOMMENDED BY THE
INSTRUCTIONS. NEVER USE THE
HEATER IN SPACES WHICH DO OR MAY
CONTAIN VOLATILE OR AIRBORNE
COMBUSTIBLES, OR PRODUCTS SUCH
AS GASOLINE, SOLVENTS, PAINT
THINNER, DUST PARTICLES OR
UNKNOWN CHEMICALS.**

WARNING:
**NOT FOR HOME
OR RECREATIONAL VEHICLE USE.**

IMPORTANT: All installations or applications of the Red Dragon Construction Heater equipment must meet the requirements of local codes. In absence of local codes, comply with the standard for the storage and handling of liquefied petroleum gases ANSI/NFPA 58. If you are still in doubt, please contact Flame Engineering, Inc. We cannot anticipate every use which may be made of our heaters.

**CHECK WITH YOUR LOCAL FIRE
SAFETY AUTHORITY IF YOU HAVE
QUESTIONS ABOUT APPLICATIONS.**

Other standards govern the use of fuel gases and heat producing products in specific applications. Your local authority can advise you about these.

FOR YOUR SAFETY:
**Do not use this heater in a space where
gasoline or other liquids having flammable
vapors are stored or used.**

Operating Instructions for the Red Dragon Construction Heater Models AG-235, AG-235A and AG-235B

2

WARNINGS

- This Heater is intended for the temporary heating of buildings under construction, alteration or repair and is not to be used for heating human living spaces. The minimum ambient temperature rating which this heater will operate is -10°F outdoor temperature.
- Heater is to be installed such that it is not directly exposed to water spray, rain, and/or dripping water.
- Adequate ventilation must be provided. DO NOT POSITION HEATER IN A LOCATION WHERE VENTILATION OR COMBUSTION AIR IS OBSTRUCTED.
- DO NOT OPERATE HEATER UNATTENDED!!
- Keep all LP-Gas cylinders at least 6 feet from Heater.
- Heater must be set level. Clearance from combustible surfaces: All sides - 4 feet; top - 8 feet from floor. Be certain no combustible materials are inside or on the heater cabinet.
- This Heater is equipped with a proof of flame safety control valve (automatic shut-off device) and nonadjustable, preset gas pressure regulator. Do not operate this heater without these controls as originally installed or make any adjustments except as explained in the Operating Instructions.

NOTE: Read and understand all operating and safety warnings and instructions before using. The operator must retain these instructions for future reference. Unpack heater and inspect for damage. Heater requires no user assembly. Contact carrier or dealer if heater shows damage.

HEATER START-UP

Propane supply cylinders used with this heater should be no less than 100 pound capacity and must be designed, fabricated, tested and marked in accordance with Regulations of the U.S. Department of Transportation, Canadian Transport Commission OR the Interstate Commerce Commission. Supply cylinders must be arranged to provide for vapor withdrawal from the operating cylinder. DO NOT PLACE ANY LP-GAS CYLINDER CLOSER THAN 6 FEET TO THE HEATER.

Minimum inlet gas supply pressure to the inlet of the regulator for purpose of input adjustment is 9.0 P.S.I.

CONNECTING TO THE SUPPLY CYLINDER

Maximum inlet gas supply pressure to the inlet of the regulator is 150 P.S.I.

1. Inspect the nipple of the P.O.L. connection on the pressure regulator for the presence of an O-ring type elastomer seal and that this seal is not cut or otherwise damaged or is brittle. Replace the seal or the nipple if the nose of nipple shows evidence of dents or physical damage.
2. Be certain the supply cylinder valve is fully turned OFF. Remove the protective plug from the cylinder valve outlet connection.

Continued on page 3

Operating Instructions for the Red Dragon Construction Heater Models AG-235, AG-235A and AG-235B

3

CONNECTING TO THE SUPPLY CYLINDER (Continued)

3. Connect the P.O.L. nut/nipple fitting on the pressure regulator to the propane supply cylinder by turning the left-hand threaded P.O.L. nut counterclockwise into the cylinder valve outlet. Snug the connection tight using a wrench on the P.O.L. nut. Do not overtighten.
4. Slowly open the cylinder valve. Check all connections in the gas supply train for leaks using soapy water or suitable leak detection solution. **DO NOT USE MATCHES OR OPEN FLAME TO CHECK FOR LEAKS.** Do not attempt to operate this heater if there is evidence of a leak or at any time the odor of gas is detected.

LIGHTING INSTRUCTIONS

WARNING: Do not operate a damaged heater!

HEATER START UP

1. Connect the P.O.L. to the propane cylinder valve.
2. Slowly open the propane cylinder valve. Check all gas supply connections to the heater for leaks with a leak detection solution (such as soapy water). Leaks will be indicated by forming bubbles around the source. Please allow one minute for leaks to appear.

WARNING: Before attempting to light heater, be certain main valve (A) is closed. The handle will be at a 90° angle in relation to the valve. (See Fig. 1)

3. Close valve (A) as indicated by the ARROW diagram located next to the valve.
4. Depress and hold the red button (B), immediately and repeatedly depress the ignitor plunger (C) until ignition is achieved while continuing to hold the red button (B).
5. Continue to hold the red button (B) FOR 15 TO 20 SECONDS after the pilot ignites. If the pilot goes out after the red button is released, repeat step 4.
6. After pilot ignition, open burner valve (A) to the on position, indicated by the ARROW diagram located next to the valve.

HEATER SHUT-OFF:

1. Close valve on propane cylinder.
2. AFTER BURNER FLAME IS NO LONGER VISIBLE, turn main heater valve (A) to the off position.

RESTART AFTER SHUT-OFF OR SAFETY SHUTDOWN:

WAIT 5 MINUTES!!

Follow start-up procedures.

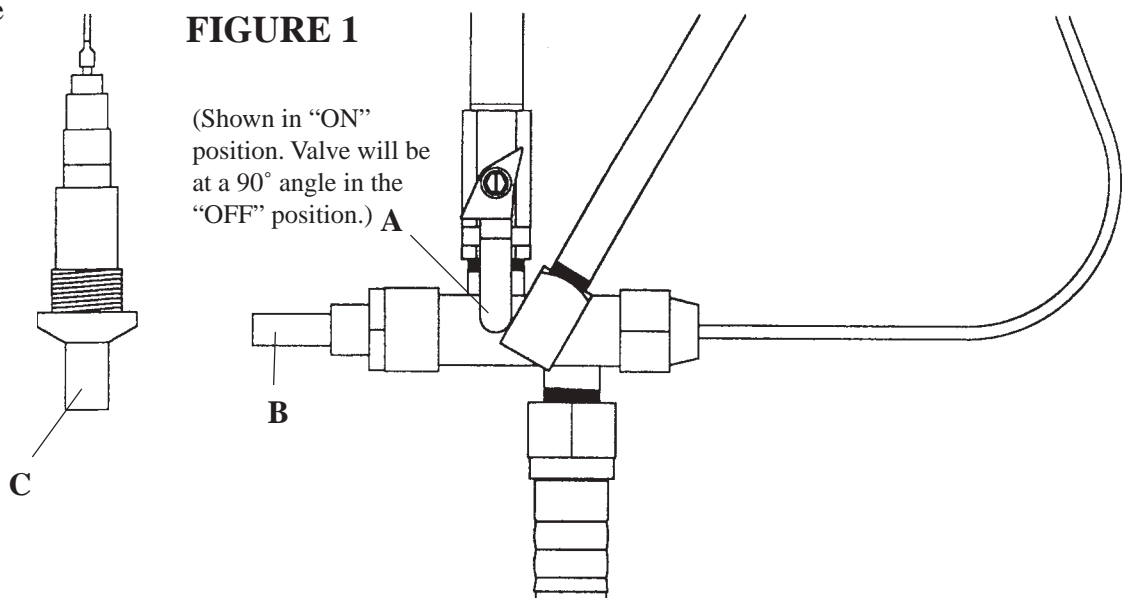

Operating Instructions for the Red Dragon Construction Heater Models AG-235, AG-235A and AG-235B

4

HEATER SHUT-OFF

1. Close the valve on the LP-gas supply cylinder. The gas must be turned off at the LP-gas supply cylinder when the heater is not in use.
2. After the burner flame is no longer visible, turn main heater valve (A) to full OFF.

DO NOT MOVE, HANDLE OR SERVICE THE HEATER WHILE SURFACES
ARE HOT OR WHILE THE HEATER IS OPERATING.

DISCONNECTING FROM SUPPLY CYLINDER:

1. Be certain supply cylinder valve is fully turned off.
2. Disconnect the P.O.L. nut/nipple fitting on the pressure regulator to the propane supply cylinder by turning the left-hand threaded P.O.L. nut clockwise to the cylinder valve outlet.
3. Replace the protective plug into the cylinder valve outlet.

RESTART AFTER SHUT-OFF OR SAFETY SHUTDOWN

WAIT 5 MINUTES

FOLLOW START-UP PROCEDURES.

In the event the burner flame goes out while the heater is in operation, a safety shutdown system will close off the supply of LP gas to the heater. After safety shutdown has occurred, reset valves according to Lighting Instructions. Do not restart heater without resetting main heater valve (A) to the OFF position. Do not make any adjustments except as explained in the Operating Instructions.

STORAGE

Never attempt to store the heater while the heater is hot or store the heater in locations where the temperature will exceed 140° F. When the heater is stored indoors, the connection between the LP-gas supply cylinder and the heater must be disconnected and the cylinder removed from the heater and stored in accordance with Chapter 5 of ANSI/NFPA 58, the standard for the storage and handling of liquefied petroleum gases. Do not store the heater in locations where it may be damaged.

WARNING: THE GAS SUPPLY HOSE SHALL BE PROTECTED FROM TRAFFIC BUILDING MATERIALS AND CONTACT WITH HOT SURFACES BOTH DURING USE AND WHILE IN STORAGE.

MAINTENANCE

- Surfaces of the heater cabinet may be cleaned with soap or detergent and water solutions. Follow manufacturer's instructions. Do not use petroleum-based cleaners to clean any components of the heater including the cabinet.

Continued on page 5

Operating Instructions for the Red Dragon Construction Heater Models AG-235, AG-235A and AG-235B

5

MAINTENANCE (continued)

- **DO NOT USE LUBRICANTS ON ANY PARTS OF THE HEATER.**
- Remove any debris and combustible materials from the heater cabinet. The heater area must be kept clear and free from combustible materials, gasoline and other flammable vapors and liquids. Check and remove obstructions in all ventilation and combustion air passages. The flow of combustion and ventilation air must not be obstructed.
- The heater should be inspected before each use and at least annually by a qualified service agency trained in the function of LP gas controls and equipment.
- The supply hose assembly shall be visually inspected prior to each use of the heater. If it is evident there is excessive abrasion or wear or the hose is cut, it must be replaced prior to putting the heater into operation. The replacement hose assembly shall be that specified by the manufacturer. See parts list.
- To remove the burner assembly, first detach the guard flash plate from the cabinet by removing two screws from each side of the plate. Remove the anchor nut. Lift the square bar from the anchor bolt and slide the burner assembly from the cabinet.
- Burner orifice may be removed for cleaning using a wrench. Consult other sections in this Operations Manual for further component information.

REPLACEMENT PARTS

Replacement Parts for the RED DRAGON Construction Heaters are available from:

FLAME ENGINEERING, INC.
P.O. Box 577, West Highway 4
LaCrosse, KS 67548
www.flameeng.com

PHONE: 785-222-2873
800/255-2469
FAX 785-222-3619

USE OF REPLACEMENT OR REPAIR COMPONENTS NOT SUPPLIED BY FLAME ENGINEERING, INC. MAY RESULT IN A SAFETY HAZARD OR UNRELIABLE HEATER PERFORMANCE.

NO WARRANTY FOR THIS PRODUCT IS EXPRESSED OR IMPLIED.

QUESTIONS? If you have any questions about the operation or assembly of the AG-235 or AG-235A call your local distributor or Flame Engineering, Inc. @ 800-255-2469.

PARTS LIST

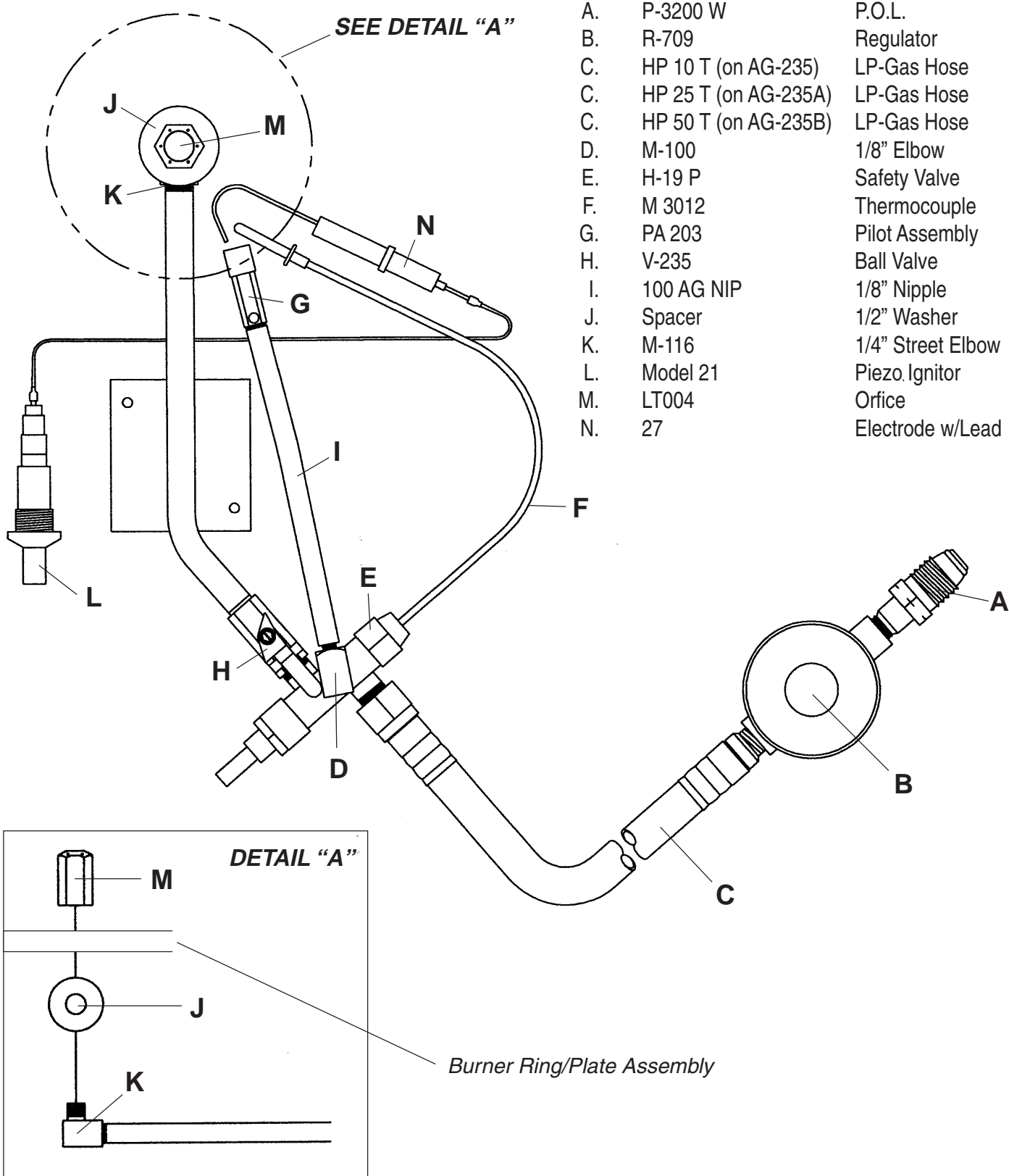

- | | | |
|----|----------------------|-------------------|
| A. | P-3200 W | P.O.L. |
| B. | R-709 | Regulator |
| C. | HP 10 T (on AG-235) | LP-Gas Hose |
| C. | HP 25 T (on AG-235A) | LP-Gas Hose |
| C. | HP 50 T (on AG-235B) | LP-Gas Hose |
| D. | M-100 | 1/8" Elbow |
| E. | H-19 P | Safety Valve |
| F. | M 3012 | Thermocouple |
| G. | PA 203 | Pilot Assembly |
| H. | V-235 | Ball Valve |
| I. | 100 AG NIP | 1/8" Nipple |
| J. | Spacer | 1/2" Washer |
| K. | M-116 | 1/4" Street Elbow |
| L. | Model 21 | Piezo Ignitor |
| M. | LT004 | Orifice |
| N. | 27 | Electrode w/Lead |

Be sure to ask about the complete line of Red Dragon heaters. For more information contact Flame Engineering, Inc. @ 800-255-2469.