

Red Dragon Back Pack Torch Kit Tank Mounting Instructions For Models: BP2512C, BP2512SVC, BP223C & BP223SVC

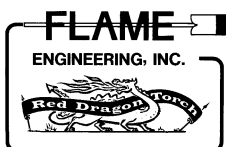

1. Place Bottom Tank Ring onto Bottom Tank Bracket.
2. Line up one of the large holes on the Top Tank Ring with the hole on the Top Tank Mounting Bracket on the back pack. Secure with bolt, fender washer and nut as shown.

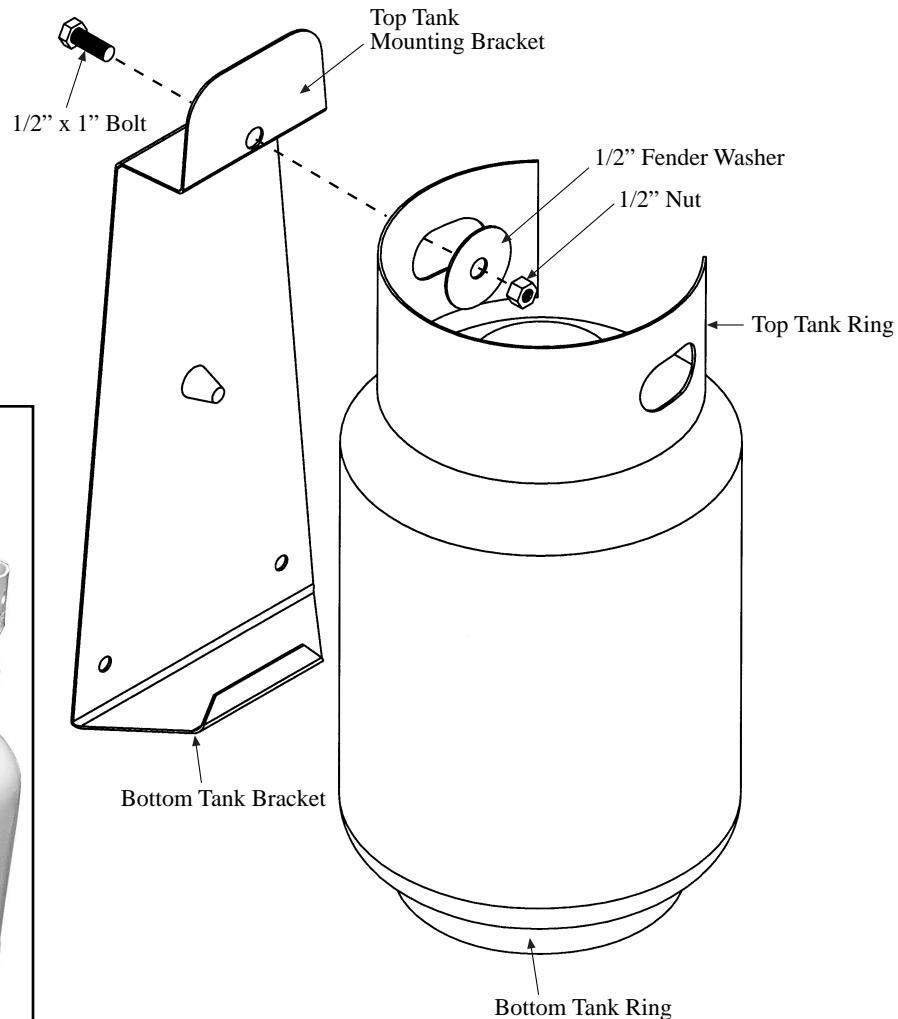

P.O. Box 577 • W. Highway 4
LaCrosse, Kansas 67548
Toll Free: 800-255-2469
785-222-2873
Fax: 785-222-3619
www.FlameEngineering.com

**Read and follow all other torch instructions
included with this kit before use.**